

Dash panel insert, mini-check system, oil pressure warning lamp, coolant monitor

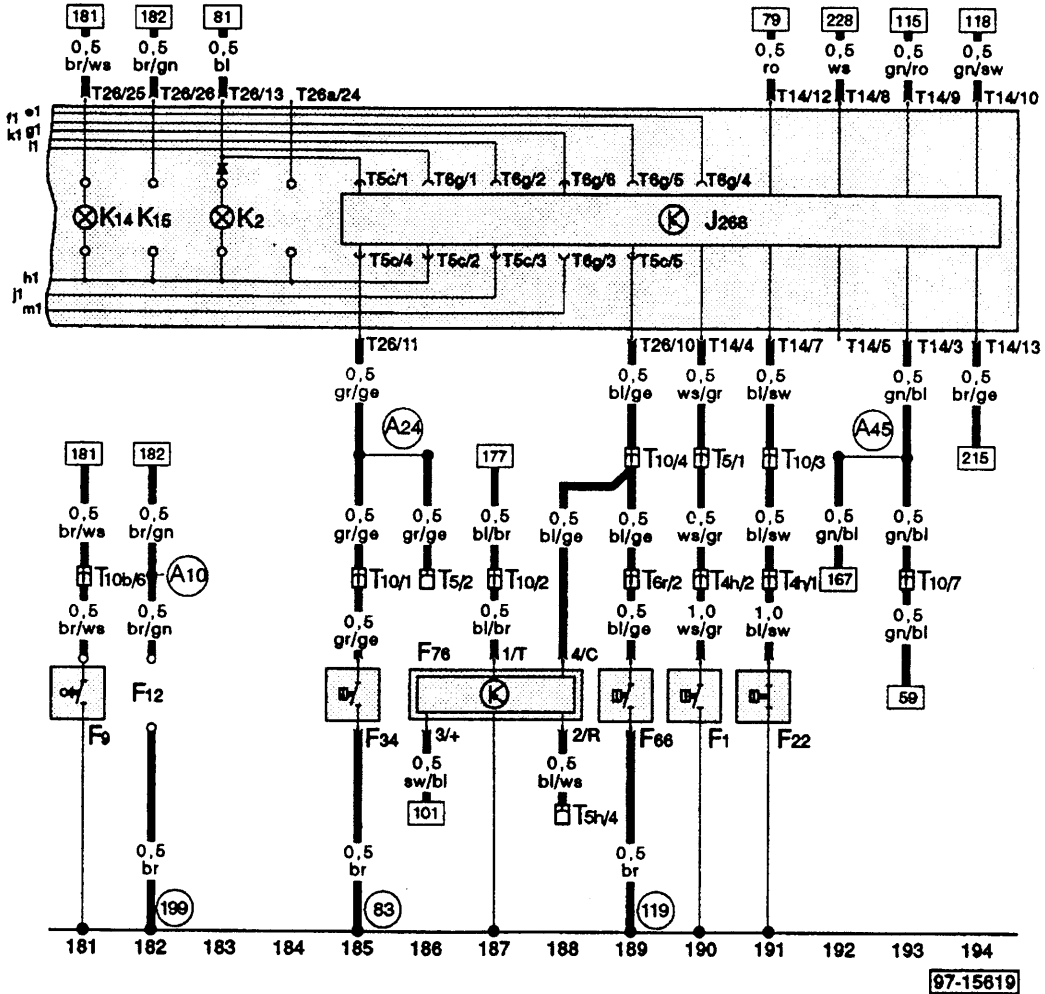
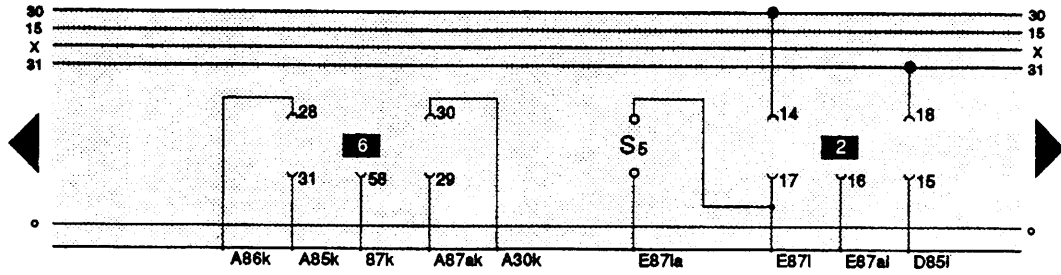

Wiring colours:

- ro = red
- sw = black
- br = brown
- ge = yellow
- gn = green
- bl = blue
- gr = grey
- ws = white
- li = purple

- F 1 – Oil pressure switch (2.5 bar)
- F 9 – Handbrake warning switch
- F 12 – Cold start warning system contact
- F 22 – Oil pressure switch (0.3 bar)
- F 34 – Brake fluid level warning contact
- F 66 – Coolant shortage indicator switch
- F 76 – Electronic thermostwitch
- J 268 – Control unit for mini-check-system
- K 2 – Alternator warning lamp
- K 14 – Handbrake warning lamp
- K 15 – Starting device warning lamp
- T 4h – Connector 4 pin, black, in engine compartment, right
- T 5 – Connector 5 pin, black, connector point in aux. relay carrier
- T 5c – Connector 5 pin, on dash panel insert
- T 5h – Connector 5 pin, red, behind dash panel, left
- T 6g – Connector 6 pin, on dash panel insert
- T 6r – Connector 6 pin, black, behind dash panel, left
- T 10 – Connector 10 pin, black, connector point in aux. relay carrier
- T 10b – Connector 10 pin, brown, connector point in aux. relay carrier
- T 14 – Connector 14 pin, white, on dash panel insert (mini-check system)
- T 26 – Connector 26 pin, yellow, on dash panel insert
- T 26a – Connector 26 pin, blue, on dash panel insert
- (81) – Earth connection – 1 –, in dash panel wiring loom
- (83) – Earth connection – 1 –, in front right wiring loom
- (119) – Earth connection – 1 –, in headlight wiring loom
- (A10) – Connection (glow plug control) in dash panel wiring loom
- (A24) – Connection (brake system monitoring), in dash panel wiring loom
- (A45) – Connection (engine speed signal), in dash panel wiring loom