

Engine compartment, 5-cylinder, Motronic (4-valve turbo) 162 kW – Audi Coupé S 2 –  
Engine code letters 3 B  
Part I

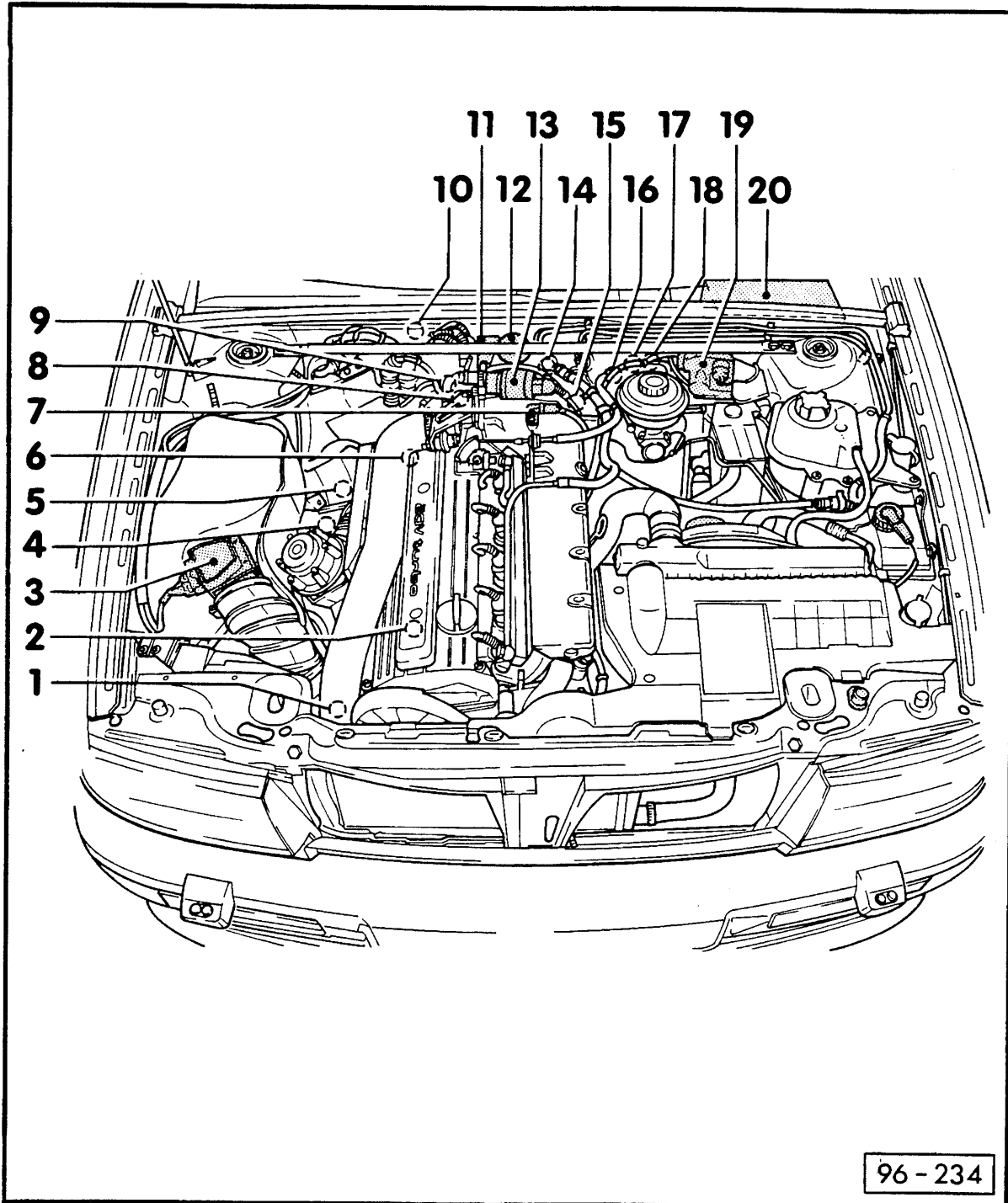

---

No.	Designation in Current Flow Diagram
1 – Solenoid valve for boost pressure limiter	–N 75
2 – Spark plug connectors/spark plugs	–Q/-P
3 – Air mass sensor	–G 70
4 – Lambda probe with heating	–G 39/-Z 19
5 – Starter	–B
6 – Coolant temperature sender (engine management)	–G 62
7 – Intake air temperature sender	–G 42
8 – Throttle potentiometer	–G 69
9 – Solenoid valve 1 for active carbon filter (pulsed)	–N 80
10 – Reversing light switch	–F 4
11 – Power stage for ignition coil	–N 70
12 – Ignition coil	–N
13 – Idling stabilization valve	–N 71
14 – Coolant temperature sender (only with air conditioner)	–G 62
15 – Distributor (Hall sender)	–O/-G 40
16 – Solenoid valve for Servotronic (on steering gear)	–N 119
17 – Speedometer sender	–G 22
18 – Warning switch for hydraulic brake servo	–F 21
19 – Pump for cruise control system	–V 18
20 – Relay plate with fuse holder	– – –

Engine compartment, 5-cylinder, Motronic (4-valve turbo) 162 kW – Audi Coupé S 2 –  
Engine code letters 3 B  
Part II

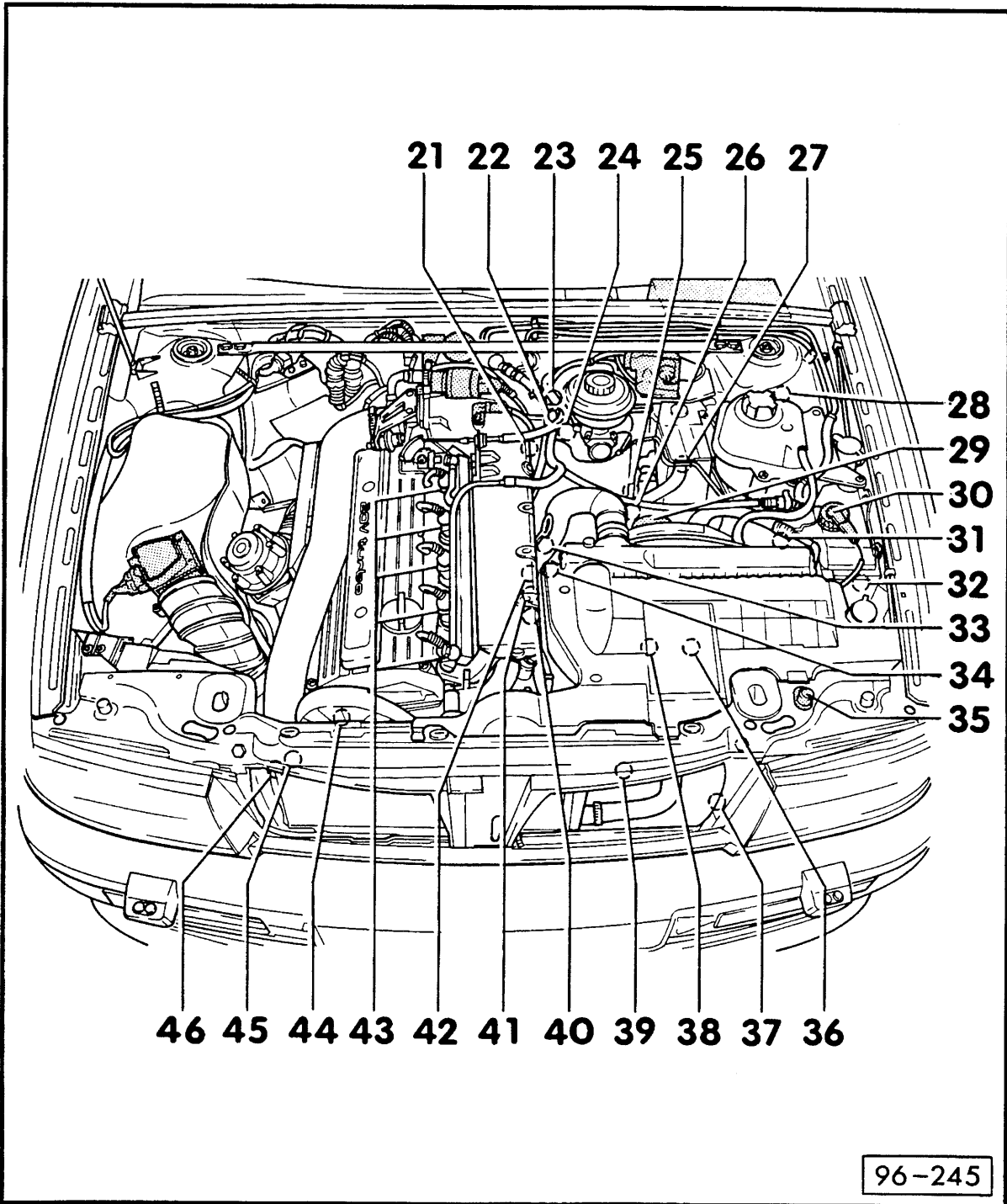

<b>No.</b>	<b>Designation in Current Flow Diagram</b>
21 – Knock sensor II	-G 66
22 – Engine speed sender	-G 28
23 – Ignition timing sender	-G 4
24 – Warning contact for brake fluid	-F 34
25 – Pump for coolant run-on (turbocharger)	-V 51
26 – Series resistance for radiator fan run-on (on radiator fan)	-N 47
27 – Hydraulic modulator for anti-lock brake system	-N 55
28 – Switch for coolant shortage indicator	-F 66
29 – Radiator fan	-V 7
30 – Warning contact for hydraulic fluid	-F 75
31 – Thermostwitch for radiator fan (integrated in one component)	-F 18/F 54
32 – Warning contact for windscreen washer fluid	-F 77
33 – Electronic thermostwitch	-F 76
34 – Thermostwitch for coolant pump (turbocharger)	-F 98
35 – Contact switch for anti-theft alarm	-F 120
36 – High-pressure switch for magnetic clutch (only with air conditioner)	-F 118
37 – Ambient temperature sensor (only with digital air conditioner or ambient temperature indicator)	-G 17
38 – High pressure switch for air conditioner	-F 23
39 – Alternator/voltage regulator	-C/-C 1
40 – Knock sensor I	-G 61
41 – Oil pressure switch 0.3 bar, combined with oil pressure sender unit (additional instruments)	-F 22/-G 10
42 – Oil pressure switch (white) 0.9 bar	-F 1
43 – Injector valves for cylinders 1/2/3/4/5	-N 30/-N 31/ -N 32/-N 33/ -N 83
44 – Oil temperature sender unit (additional instruments)	-G 8
45 – Magnetic clutch for compressor (only with air conditioner)	-N 25
46 – Protective diode for magnetic clutch (only with air conditioner)	-J 201